



**2nd Technical Conference
“Advanced Battery Technologies for Automobiles
and Their Electric Power Grid Integration”**

1-2 February 2010, Rheingoldhalle, Mainz

Lifetime Models for Lithium-ion Batteries

Clemens Günther, Andreas Jossen, Volker Späth

Zentrum für Sonnenenergie- und Wasserstoff-Forschung (ZSW) Baden Württemberg
(Center for Solar Energy and Hydrogen Research)



Overview

- Motivation
- Battery model
- Aging – definitions and assumptions
- Two approaches for lifetime modeling
- Optimal design and control
- Summary and future work



Motivation



“Grid Integration of Electrical Power Train Systems in Existing and Future Energy Supply Structures”

The project is funded by the German Federal Ministry of Economics and Technology (BMW) within the framework of the “national development plan for electric mobility”

Example: Battery electric vehicle (BEV) and grid services

- Investment costs of accumulator $K=1000 \text{ €/kWh} \cdot 35 \text{ kWh}=35000 \text{ €}$

- High load

- Early battery breakdown
- Constructive total loss
- Possible answer:
State of health evaluation
lifetime prediction

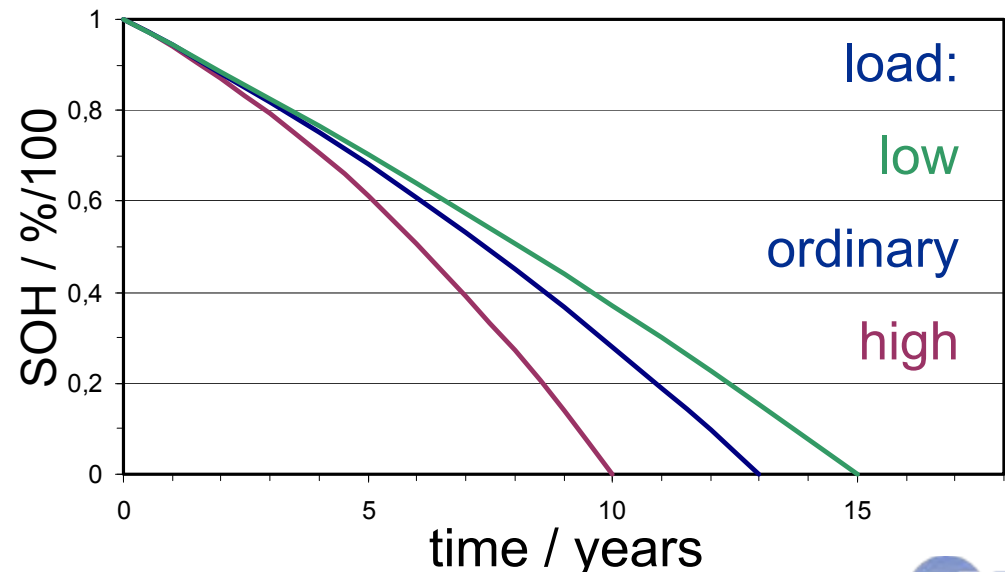



Battery Model

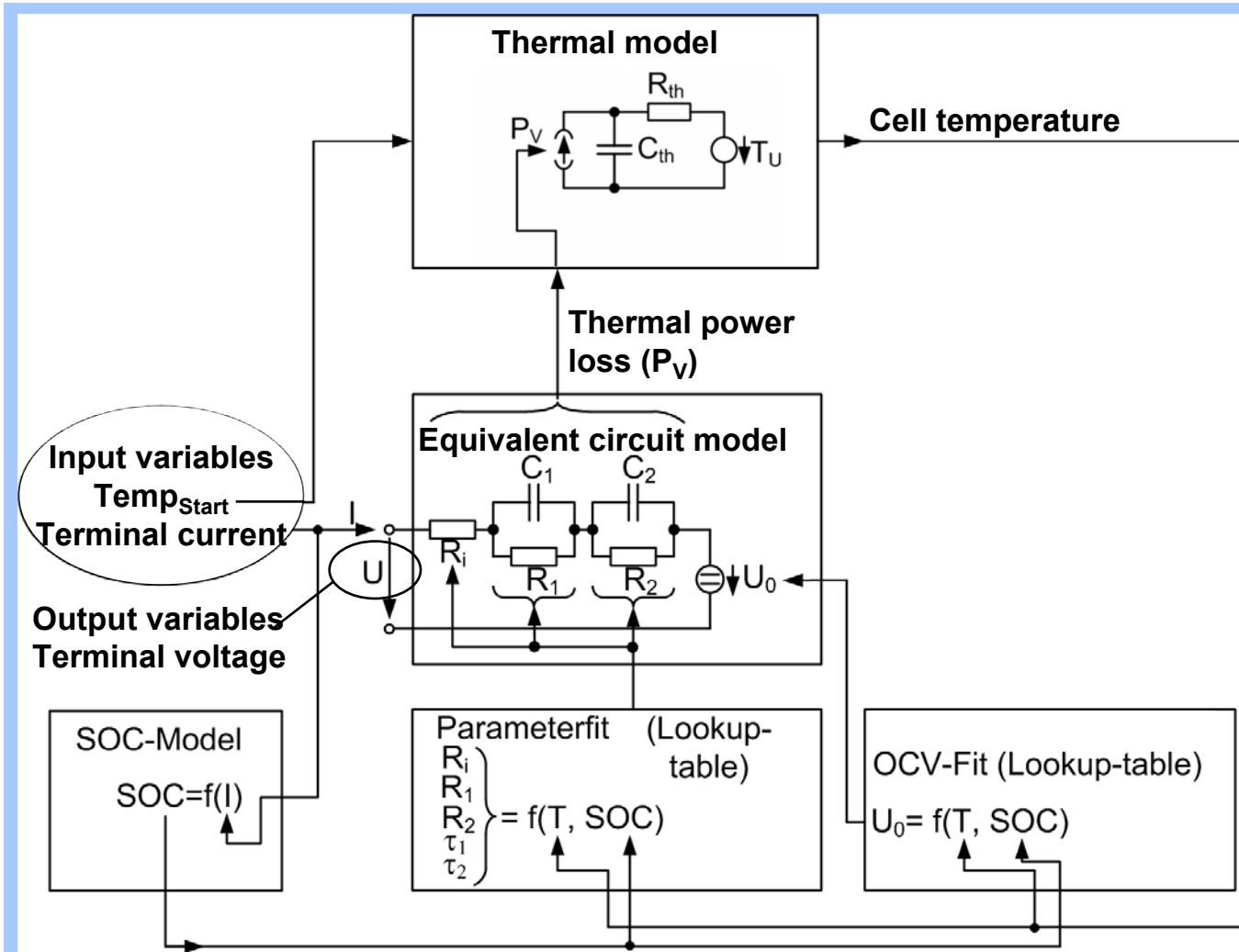

Test series for parameterization

- current pulses
 → resistances and time constants
- open circuit voltage
- thermal behavior and cell design

Herb, F., M. Beißwenger und A. Jossen: *LiFePO4 Alterungsmodellierung*. In *Proceedings des 16. Entwicklerforums Batterien, Ladekonzepte und Stromversorgungsdesign*, München, Deutschland, 2009, DESIGN&ELEKTRONIK



Aging, End of Life and State of Health

Aging

Chemical and electrochemical reactions change characteristics of cells

- decreasing capacity C
- increasing internal resistance R_i

End of Life (EOL): $C_{EOL} = \alpha_C C_N$ or $R_{i,EOL} = \alpha_R R_{i0}$

Age: $A = f(\alpha_C, \alpha_R, C, R_i); 0 \leq A \leq 1$

For example: $A = \max\left\{ \frac{1 - C/C_N}{1 - \alpha_C}, \frac{1 - R_i/R_{i0}}{1 - \alpha_R} \right\}$

State of health (SOH): $SOH = 1 - A; 0 \leq SOH \leq 1$

Example for begin of life (BOL):

$$C_{BOL} = C_N, R_{i,BOL} = R_{i0}, A = 0 \text{ und } SOH = 1$$



Two Approaches for Lifetime Modeling

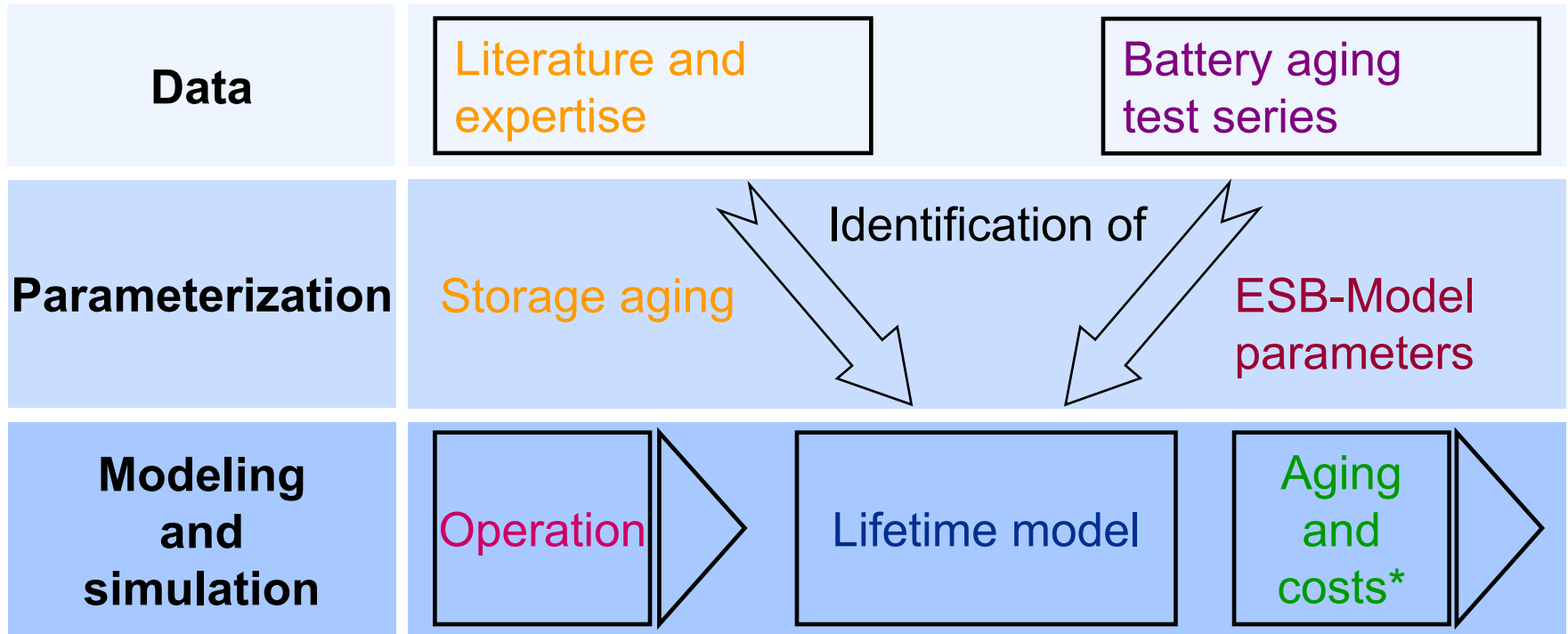

*) "Costs for an operation are based on the effective aging per cycle"



“Literature Based” Aging Model (1)

Assumptions

- $A_{\text{cal}} = f(T, \text{SOC}); A_{\text{cycl}} = f(\Delta \text{SOC})$
- $A_{\text{tot}} = A_{\text{cal}} + A_{\text{cycl}}$
- doubled aging speed:
voltage increase about 100 mV
temperature increase by 10 K – 15 K

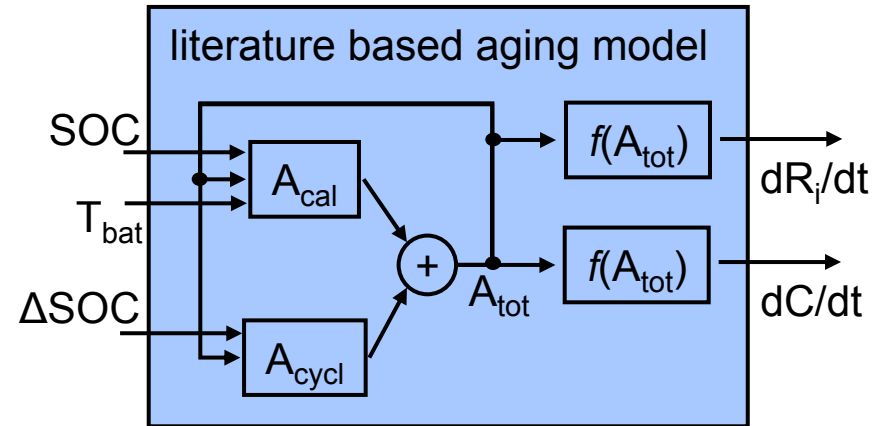

Aging functions

- Calendar aging speed: $a_{\text{cal}} = a_0 \cdot \exp(b \cdot (\text{SOC} - \text{SOC}_0)/c) \cdot \exp((T - T_0)/d)$
- Aging per cycle: $A = a_3 \cdot \text{DOD}^3 + a_2 \cdot \text{DOD}^2 + a_1 \cdot \text{DOD} + a_0$



“Literature Based” Aging Model (2)

Parameterization

- Specific parameters for different chemical systems

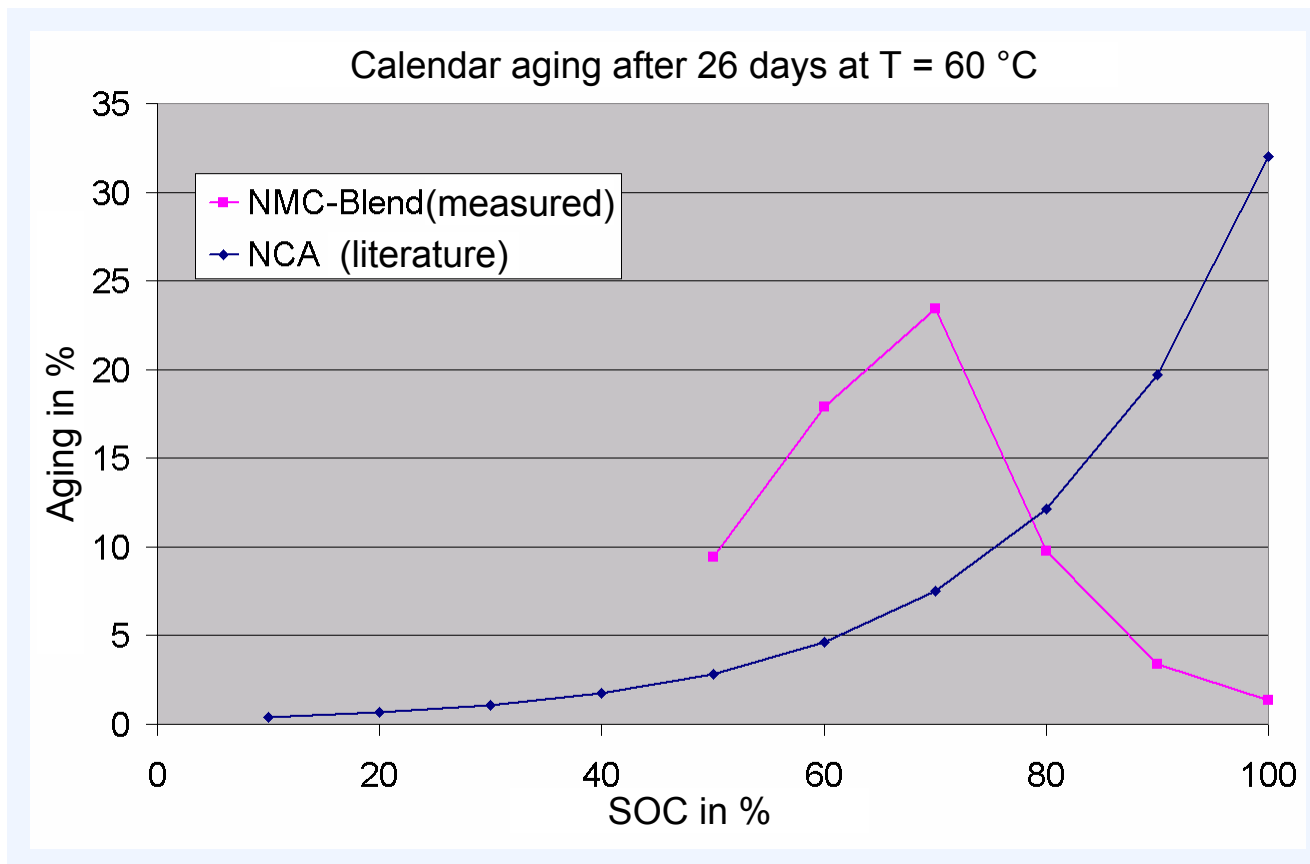



“Literature Based” Aging Model (3)

Input variables

- ✓ cell temperature T ← battery model
- ✓ state of charge SOC ← battery model
- ? depth of cycle ΔSOC → Problem: Cycle analysis

Example

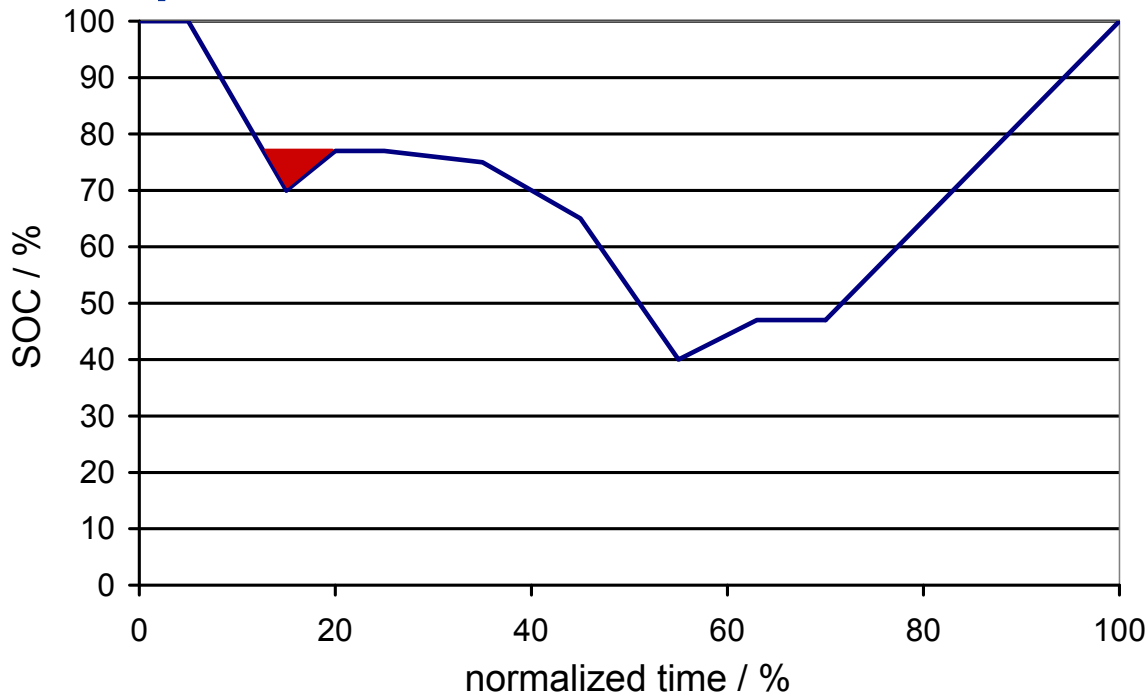

Approach: Algorithm for identification of subcycles by locating maxima and minima in $SOC = f(t)$

→ Two subcycles:

$$\Delta SOC = 7 \%$$

$$\Delta SOC = 60 \%$$



Comparison of Simulation Results and Reference Data (1)

Difference between reference and simulated values

- Results for calendar aging speed (SOC = 50 %)

T in °C	Minimal Δa_{cal} in %/a *)	Maximal Δa_{cal} in %/a *)
20	0,00003	0,02094
40	0,00006	0,10704
80	37,09553	39,92024

→ Good results within relevant temperature range!

*) Simulations with variable step size h_v and different upper limits $h_{v,max}$

- Results for Cycle life ($\overline{SOC} = 50 \%$)

ΔSOC in %	Maximum variable step size $h_{v,max}$ in s	ΔSOH_{EOL} in %	ΔC_{EOL} in $1/C_N$ *)
25	40	8.03914	0.01607
50	20	6.00804	0.01201
100	5	2.68759	0.00537

→ Small differences in capacity loss!

*) Precondition $C_{EOL} = 0,8 \cdot C_N$



Simulation of Driving Cycles (1)



Driving cycle (TU Berlin, ILS – KFZ)

Smart four four $\rightarrow v = f(t) \rightarrow$ vehicle model simulation $\rightarrow P_{el}$

Charging

3.68 kW

Battery

35 kWh, 150 kW

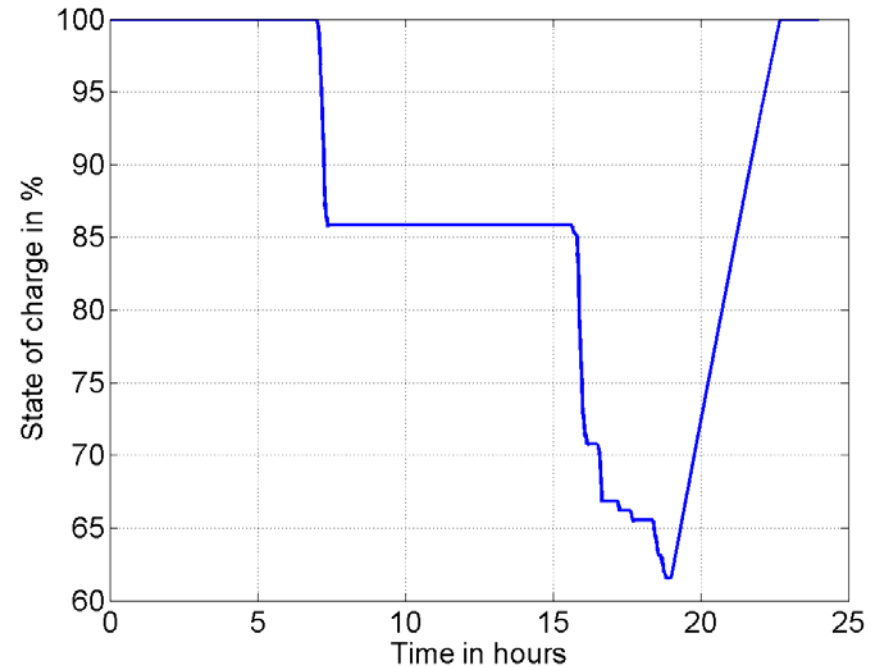
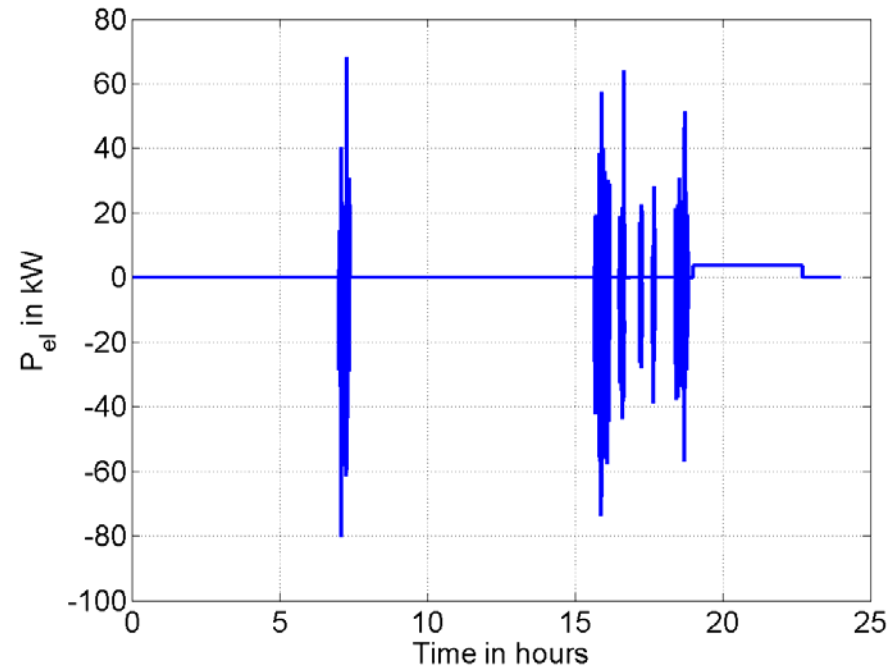



Simulation of Driving Cycles (2)



Aging per Cycle

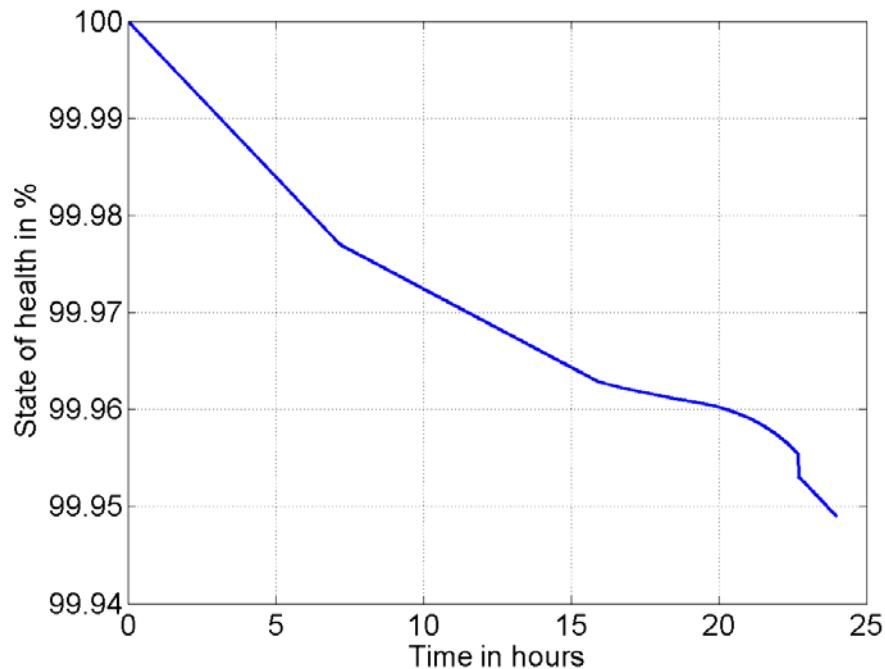

Lower SOC extends lifetime! ←

End of Life

Extrapolation from 90 Days to EOL

Charge Daily 19 p.m., 3 a.m.

Charge every other day 23 p.m.

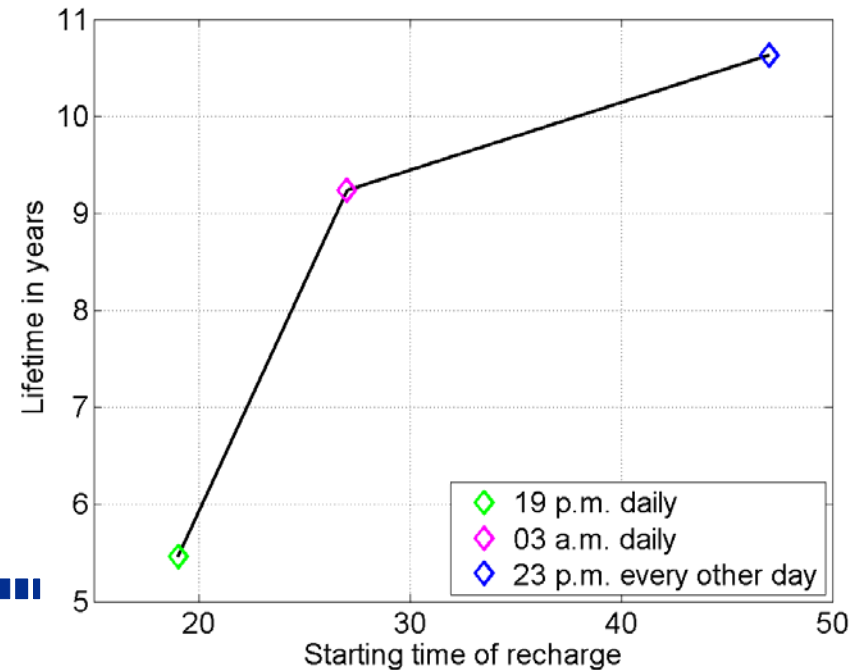



“Test Series Based” Aging Model (1)

Structure of “test series based” aging model

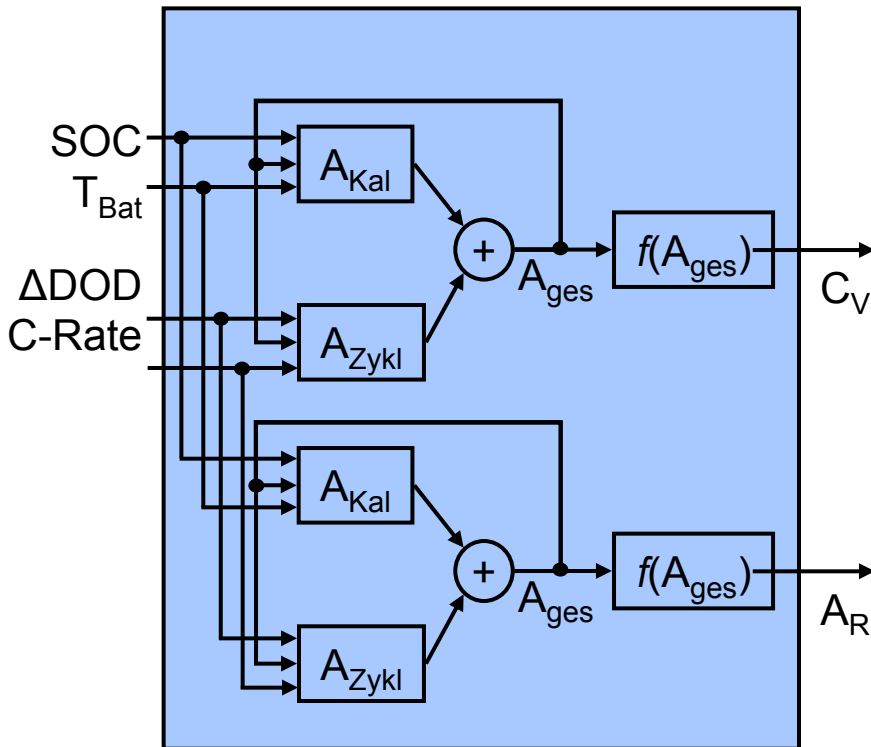

- Storage aging test series
- OCV measurements
- Thermal behavior
- Gravimetric analysis

Pack	Anz.	Korr.	Temp.	delta DoD	max Amp.	mit. SoC
p1	4	T	40 °C	0%	0 C	60%
p2	4	T,D,A,S	50 °C	0%	0 C	60%
p3	4	T	70 °C	0%	0 C	60%
p4	4	S	50 °C	0%	0 C	30%
p5	4	S	50 °C	0%	0 C	80%
p6	4	D	50 °C	5%	5 C	60%
p7	4	T-D	50 °C	10%	5 C	60%
p8	4	D,A	50 °C	10%	20 C	60%
p9	4	T-D	40 °C	30%	20 C	60%
p10	4	D	50 °C	30%	20 C	60%
p11	4	D	50 °C	60%	20 C	60%
p12	4	D	50 °C	30%	30 C	60%
p13	4	D-A	50 °C	60%	5 C	60%
p14	4	A	50 °C	var	var	var

Herb, F., M. Beißwenger und A. Jossen: *LiFePO4 Alterungsmodellierung*. In *Proceedings des 16. Entwicklerforums Batterien, Ladekonzepte und Stromversorgungsdesign*, München, Deutschland, 2009, DESIGN&ELEKTRONIK

clemens.quenther@zsw-bw.de





“Test Series Based” Aging Model (2)

Relative capacity loss with verification cells

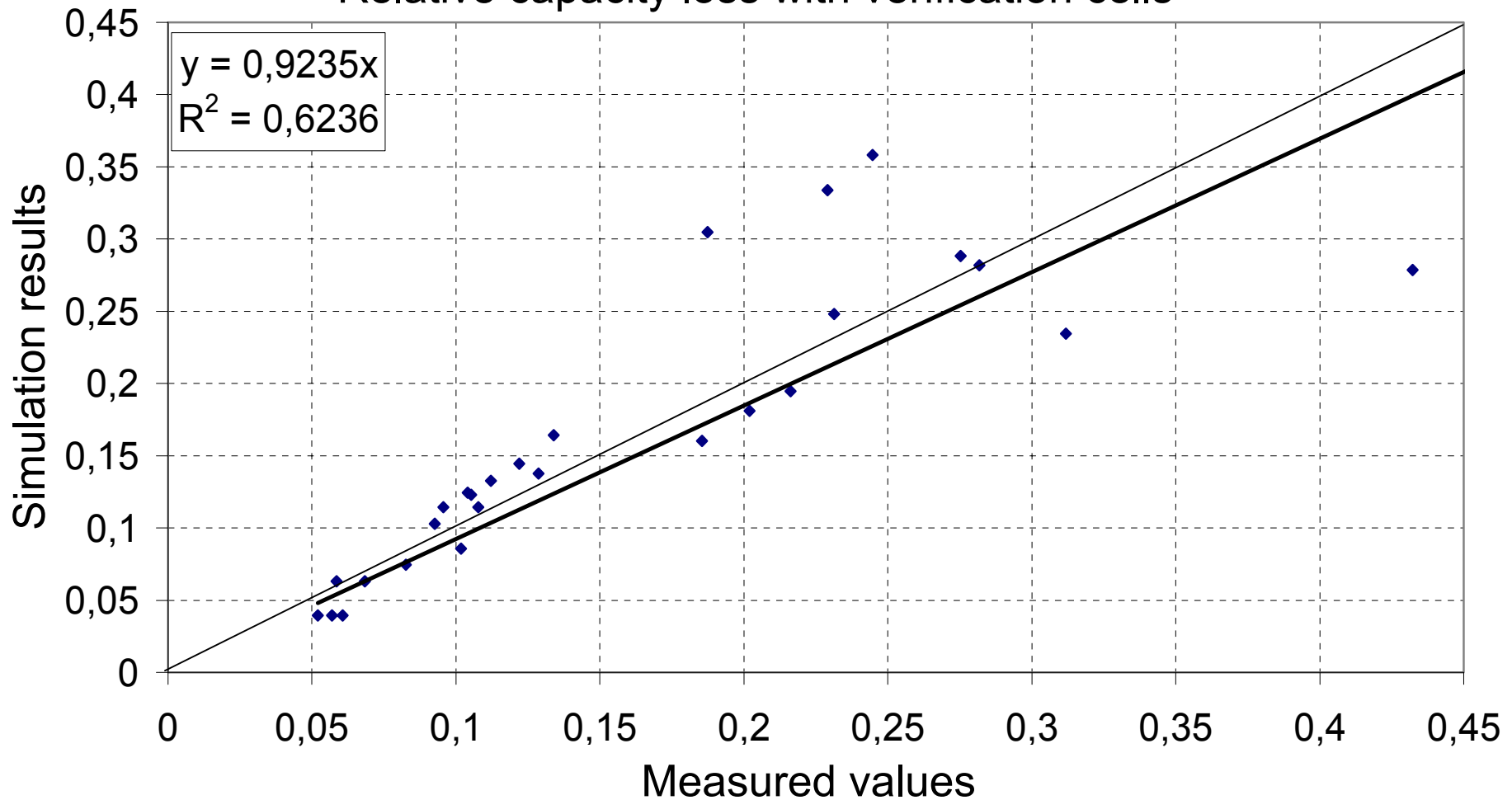

Herb, F., M. Beißwenger und A. Jossen: *LiFePO4 Alterungsmodellierung*. In *Proceedings des 16. Entwicklerforums Batterien, Ladekonzepte und Stromversorgungsdesign*, München, Deutschland, 2009, DESIGN&ELEKTRONIK

clemens.quentner@zsw-bw.de





Optimal Offline Design of Battery and Battery Management System

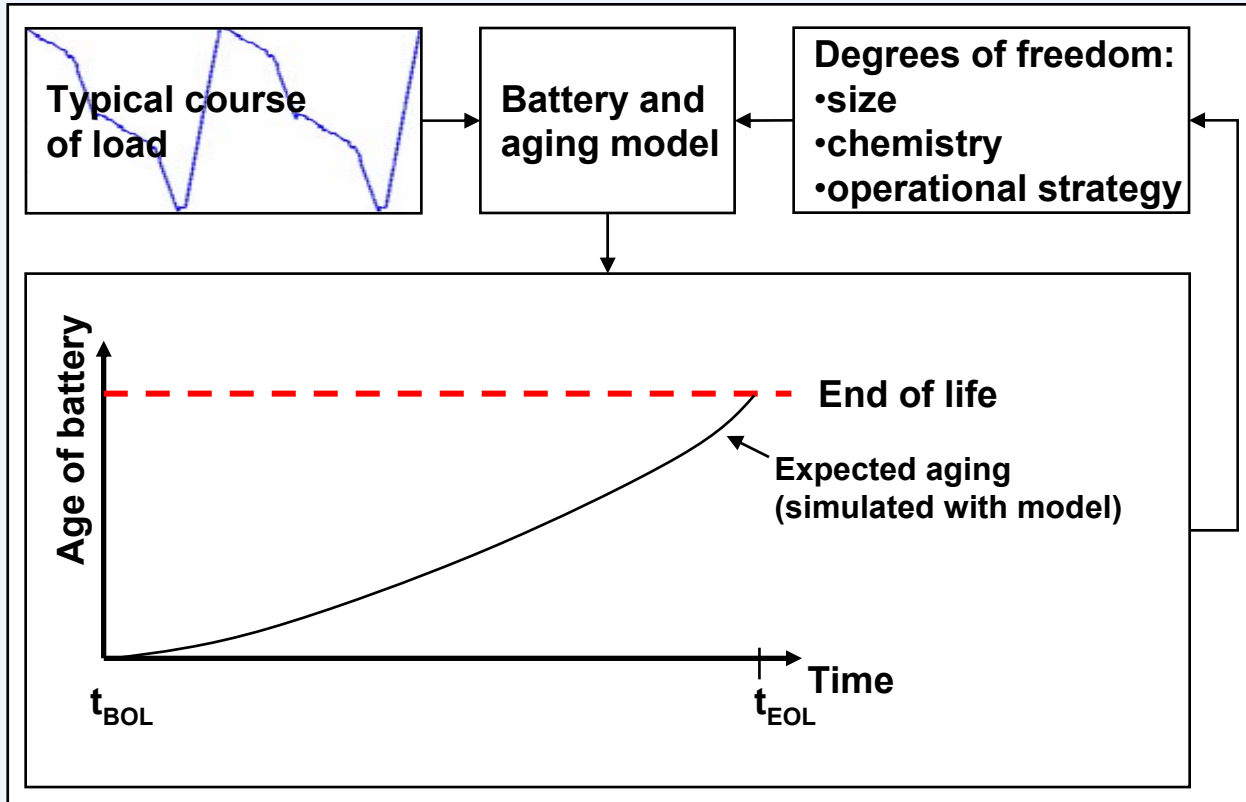



Optimization of Operation

If degrees of freedom exist:

- Adapt cycling to battery reference lifetime
- SOC in range of low aging
→ slower calendar aging

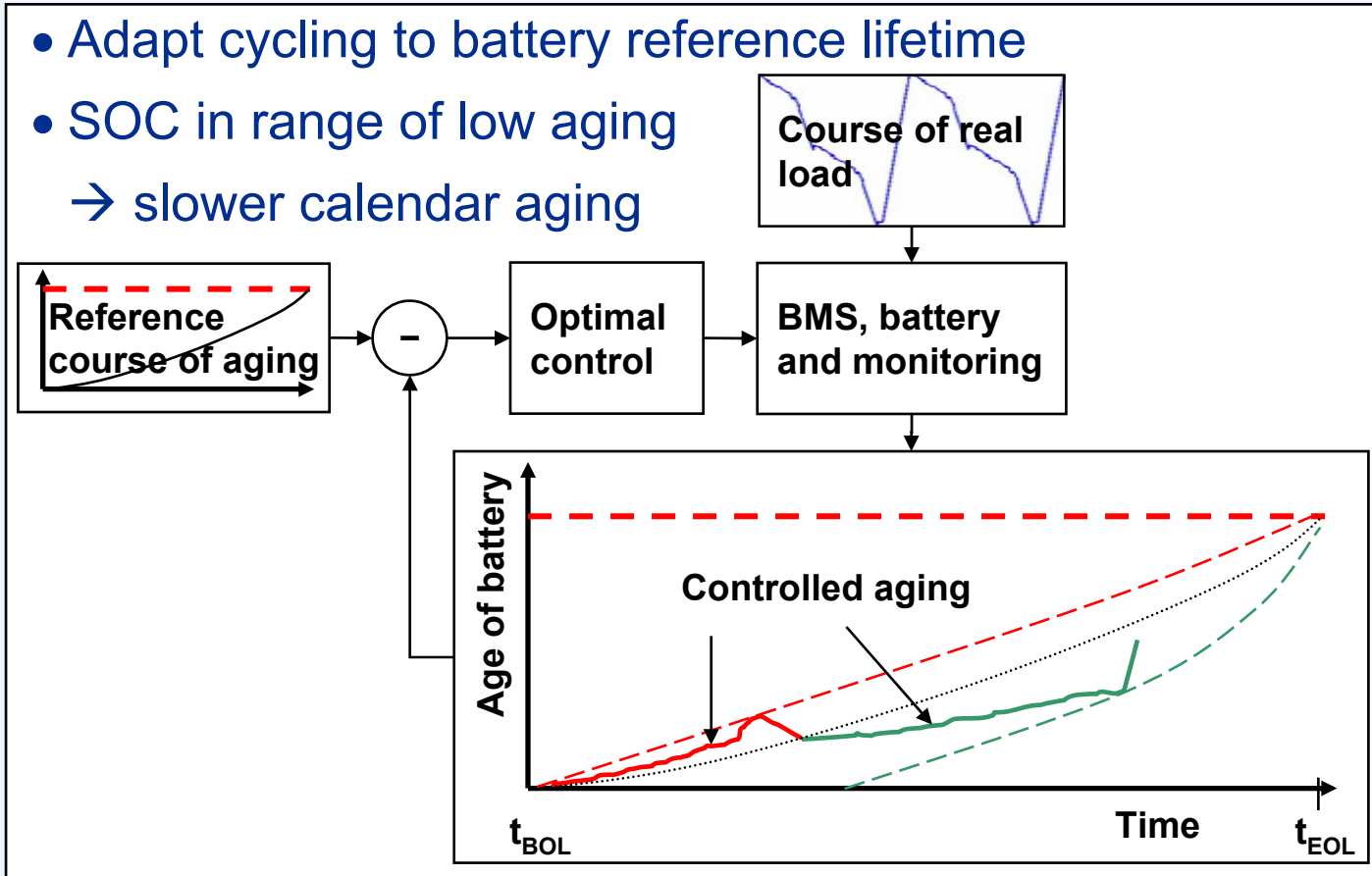



Summary and Future Work

- Two different approaches for lifetime models are presented
 - Fast parameterization with literature data
 - More detailed parameterization with lifetime test series
- An algorithm for analyzing driving cycles is presented
- We are able to estimate costs for simulated loads like grid services
- “Literature based“ model
 - Verification with own measurements
 - More detailed assumptions
 - Simulate aging for grid services
 - Generate more sets of parameters
- Parameterization of “test series based” model for different cell types
- Optimal system design and optimized operation



ZSW is Well-Positioned

– Research and Development Partner –

Zentrum für Sonnenenergie- und Wasserstoff-Forschung
Baden-Württemberg
Department Accumulators
Helmholtzstraße 8
89081 Ulm

Activities:

- Fuel cells
- Photovoltaics
- **Accumulators**
- Renewable fuels
- System analysis and engineering

**Thank you for
your attention!**



Solar Test Field,
ZSW Widderstall



Photovoltaics,
ZSW Stuttgart



Electrochemical Energy
Technologies, ZSW Ulm